

# Lift trucks

# 9–18 tonnes

---

Kalmar DCG90-180  
9–18 tonnes capacity

---

Technical information



# Designed to deliver greater total lifetime savings

The DCG90-180 is a range of new Kalmar trucks with a lifting capacity of 9 – 18 tonnes. The new DCG90-180 is the result of our customer-focused product development activities as well as our deep commitment to improving the performance of lift trucks. In fact, DCG90-180 capitalizes on insights we have gained from the more than 10.000 worldwide users of Kalmar trucks with this lifting capacity.

**Introducing Kalmar DCG90-180**  
The new Kalmar DCG90-180 is designed, built and delivered to offer greater total lifetime savings. This new range of Kalmar trucks offer these savings by improving the performance of your truck-and-driver teams. Below is a summary of how the Kalmar DCG90-180 benefits your business.

**Give your savings a lift**  
The following pages provide you more details about the Kalmar DCG90-180. Contact your local Kalmar representative for a closer look and a test drive.

## Model designation

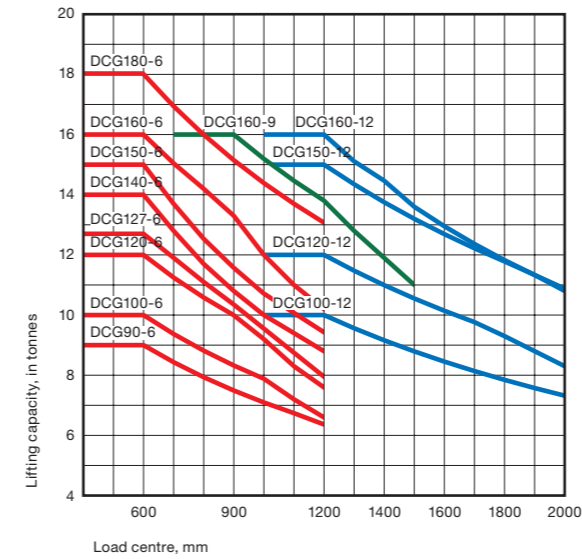
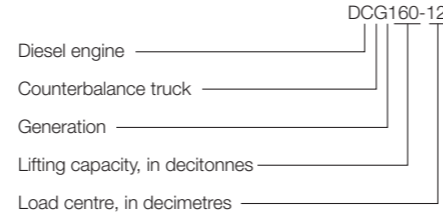

DCG90-6 to DCG180-6 models:  
Full lifting capacity up to 5000 mm lift height with duplex/duplex freelif/triplex masts and integrated sideshift/fork positioning carriage.

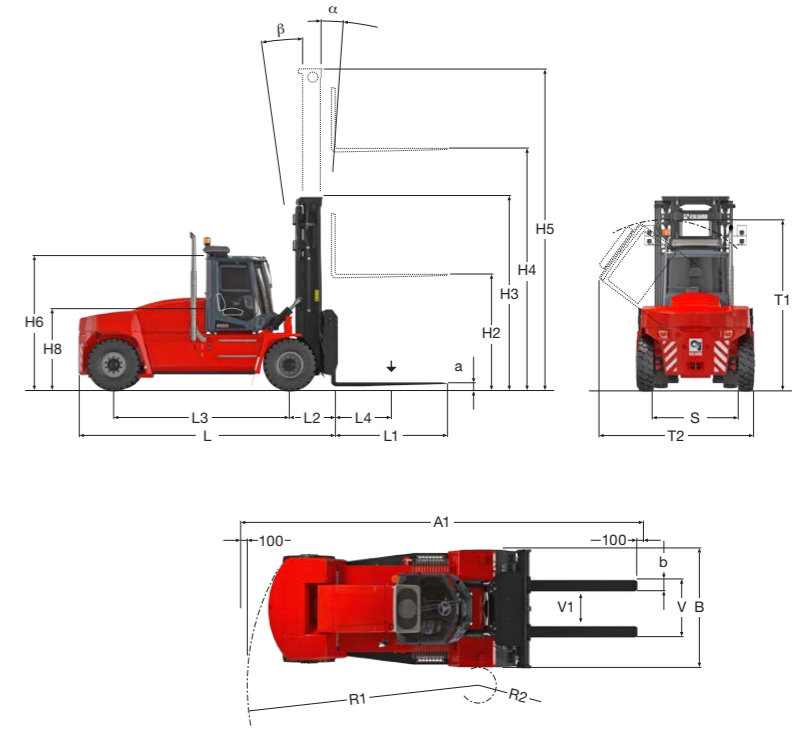

Dimensions		DCG90-6	DCG100-6	DCG120-6	DCG127-6	DCG140-6	DCG150-6	DCG100-12	DCG120-12	DCG150-12	DCG160-6	DCG160-9	DCG160-12	DCG180-6	DCG70-32 E3	DCG70-35 E4	
Lifting capacity	Rated (kg)	9000	10000	12000	12700	14000	15000	10000	12000	15000	16000	16000	16000	18000	7000	7000	
	Load centre (mm)	L4	600	600	600	600	600	600	1200	1200	12000	600	900	1200	600	1220	1220
Truck	Truck length (mm)	L	4470	4720	4725	4725	4985	5055	5065	5315	5325	5305	5315	5575	5065	5595	5845
	Truck width (mm)	B	2480	2480	2480	2480	2480	2540	2540	2540	2540	2540	2540	2540	2540	2540	2900
	Height, basic machine, EGO cabin (mm)	H6	2895	2895	2895	2920	2920	2920	2920	2920	2920	2920	2920	2920	2920	2920	2920
	Height, basic machine, EGO cabin, OHG (mm)	H6	2895	2895	2895	2895	2895	2895	2895	2895	2895	2895	2895	2895	2895	2895	2895
	Seat height, EGO cabin (mm)	H8	1770	1770	1770	1790	1770	1770	1770	1770	1770	1770	1770	1770	1770	1770	
	Distance between centre of front axle – front face of fork arm (mm)	L2	895	895	900	900	910	980	990	–	1000	980	990	1000	990	1265	1265
	Wheelbase (mm)	L3	2800	3000	3000	3000	3250	3250	3250	3500	3500	3500	3500	3750	3250	3250	3500
	Track (c-c), front – rear (mm)	S	1840 – 1960	1840 – 1960	1840 – 1960	1840 – 1960	1855 – 1960	1855 – 1960	1855 – 1960	1855 – 1960	1855 – 1960	1855 – 1960	1855 – 1960	1855 – 1960	1855 – 1960	1855 – 1960	2210 – 1960
	Turning radius, outer – inner (mm)	R1 – R2	3950 – 75	4180 – 75	4180 – 75	4180 – 75	4360 – 125	4360 – 125	4360 – 125	4785 – 420	4785 – 420	4785 – 420	4785 – 420	5175 – 600	4570 – 270	4360 – 125	4785 – 420
	Ground clearance, min. (mm)		330	330	330	330	350	350	350	350	350	350	350	350	350	350	350
	Height when tilting cab, max. EGO cabin, OHG (mm)	T1	3370	3370	3370	3395	3395	3395	3395	3395	3395	3395	3395	3395	3395	3395	3395
	Width when tilting cab, max. EGO cabin, OHG (mm)	T2	3350	3350	3350	3380	3380	3380	3380	3380	3380	3380	3380	3380	3380	3380	
	Min. aisle width for 90° stacking with forks (mm)	A1	6240	6470	6475	6475	6665	6735	6745	6870	8380	7160	8160	8770	6745	8900/13800	9200/13900
Standard duplex mast	Lifting height (mm)	H4	5000	5000	5000	5000	5000	5000	5000	5000	5000	5000	5000	5000	7000	10000	
	Mast height, min. (mm)	H3	4015	4015	4015	4035	4035	4195	4195	4195	4195	4195	4195	4195	5195	7075	
	Mast height, max (mm)	H5	6515	6515	6515	6535	6535	6695	6695	6695	6695	6695	6695	6695	8695	12075	
	Mast tilting, forward – backward (°)	$\alpha - \beta$	5 – 10	5 – 10	5 – 10	5 – 10	5 – 10	5 – 10	5 – 10	5 – 10	5 – 10	5 – 10	5 – 10	5 – 10	3 – 5	3 – 5	
	Ground clearance, min. (mm)		250	250	250	250	250	250	250	250	250	250	250	250	250	250	
Forks	Width (mm)	b	200	200	200	200	200	200	220	250	200	220	250	220	6064	6064	
	Thickness (mm)	a	65	65	70	70	80	80	90	90	80	90	100	90	2120	2120	
	Length of fork arm (mm)	l	1200	1200	1200	1200	1200	1200	2400	2400	1200	1800	2400	1200	–	–	
	Width across fork arms, max. – min. (mm)	V	2330 – 570	2330 – 570	2330 – 570	2330 – 570	2330 – 570	2360 – 600	2360 – 640	2360 – 700	2360 – 600	2360 – 640	2360 – 700	2360 – 640	–	–	
	Sideshift $\pm$ at width across fork arms (mm)	V1 – V	440 – 1450	440 – 1450	440 – 1450	440 – 1450	440 – 1450	440 – 1480	430 – 1500	430 – 1500	430 – 1530	440 – 1480	430 – 1500	415 – 1530	430 – 1500	140	140
Weight	Service weight (kg)		15200	15600	16200	16700	16900	19800	18600	19700	22300	19200	21200	22400	21600	22900	23900
	Axle load front, unloaded (kg)		7800	8100	8300	8300	8400	10300	10000	10100	10200	10200	10200	10500	10300	14700	15600
	Axle load front, at rated load (kg)		21700	23100	26500	27350	28900	32650	26700	29600	34600	34800	34800	35800	37100	27100	27600
	Axle load back, unloaded (kg)		7400	7500	7900	8400	8500	9500	8600	9600	12000	11000	11000	11900	11300	8200	8300
	Axle load back, at rated load (kg)		2500	2500	1900	2050	2000	2150	1900	2100	2600	2400	2400	2600	2500	2800	3300
Wheels / tyres	Type, front – rear		Pneumatic – Pneumatic				Pneumatic – Pneumatic										
	Dimensions, front – rear / ply (inch)		11,00x20/16PR	11,00x20/16PR	11,00x20/16PR	12,00x20/20PR	12,00x20/20PR	12,00x20/20PR	12,00x20/20PR	12,00x20/20PR	12,00x20/20PR	12,00x20/20PR	12,00x20/20PR	12,00x20/20PR	12,00x20/20PR	12,00x20/20PR	12,00x20/20PR
	Number of wheels, front – rear (*driven)		4* – 2	4* – 2	4* – 2	4* – 2	4* – 2	4* – 2	4* – 2	4* – 2	4* – 2	4* – 2	4* – 2	4* – 2	4* – 2	4* – 2	4* – 2
	Pressure (Mpa)		0,9	0,9	0,9	0,9	0,9	0,9	0,9	0,9	0,9	0,9	1,0	1,0	1,0	0,9	0,9
Steering system	Type – manoeuvring		Hydraulic servo – Steering wheel				Hydraulic servo – Steering wheel										
Service brake system	Type – affected wheels		Oil cooled disc brakes (Wet disc brakes) – drive wheels				Oil cooled disc brakes (Wet disc brakes) – drive wheels										
Parking brake system	Type – affected wheels		Dry, spring activated disc brake – drive wheels				Dry, spring activated disc brake – drive wheels										
Hydraulic pressure	Max. (Mpa)		16,0	17,0	17,5	18,0	19,0	16,5	12,5	15,0	17,0	17,0	17,5	18,0	19,0	19,5	20,0
Hydraulic fluid volume	(l)		215	220	220	220	220	220	220	220	220	220	220	220	220	220	220
Fuel volume	(l)		152	170	170	170	170	170	170	170	170	170	170	170	170	170	170
AdBlue volume*	(l)		15	15	15	15	15	15	15	15	15	15	15	15	15	15	

\*Only Volvo TAD761VE

# New EGO cabin: our most productive driving environment. Ever.

Improving a driver's working environment – the cabin – stimulates productivity, efficiency and safety. That's why the new DCG90-180 incorporates our most productive driving environment: the new EGO cabin. It's loaded with outstanding ergonomics and smart features that help drivers optimally perform their work. As important, the truck has new electric and hydraulic systems as well as modern lifting equipment to help drivers boost productivity and operational savings.

## EGO cabin enables driver productivity

The new EGO cabin is a spacious workplace. Its curved glass window gives the operator excellent side-to-side and overhead visibility. Below is a closer look at some of the interior of DCG90-180.

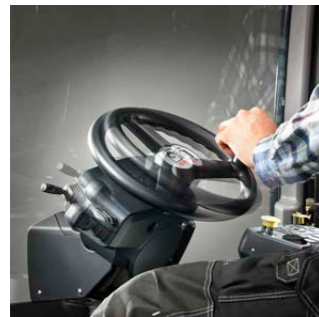

### Ergonomic steering wheel

It's adjustable and can also be tilted to the side. This decreases stress on the operator during driving and reversing.



### Comfort pedals

A new flexible and safe pedal system with an adjustable pedal angle. Improves ergonomics and minimizes strain on the driver's foot. A floor-based solution gives a hanging pedal feel.



### Windshield wipers

Provides over 90% coverage of the curved front window. Roof wipers are also integrated. It all means superior visibility and safety.

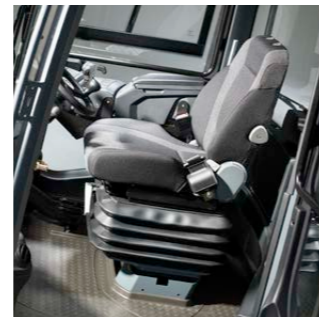

### Ergonomic multi-seat

Rotatable and fully integrated. Built for maximum sitting posture, comfort and ergonomics during long shifts and demanding operations.

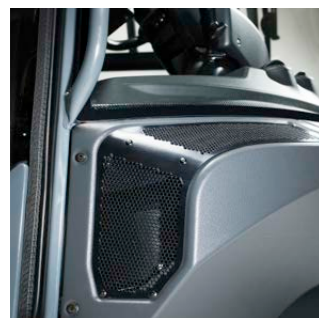

### Climate package

Complete and flexible climate control system that matches the high demands of the climate tested EGO cabin. Large air intakes. Easy filter replacement in the front. Complete driving comfort from well-dimensioned and -designed components.



### Work console

Easy to set, adjust, use and understand. All necessary controls, switches, levers and indicators easily accessible for effective operations. Clear and well-placed panels and steering wheel controls for data display.



### Operating console

The complete unit for operators who use the mini-wheel or steering lever. Integrated gear knobs. Fully adjustable and individually tested for optimal ergonomics. The ergonomic steering wheel is folded forward without limiting vision.

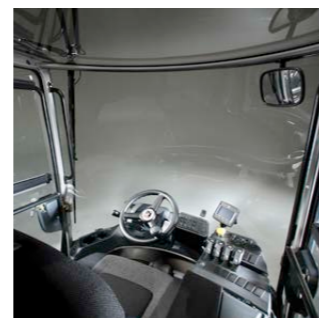

### Optimized visibility

Completely new open design. Designed with smart profiles and curved front and rear windows. An optimized view at all angles, with an exceptionally good view diagonally forwards and backwards. Strong outdoors feeling.

# Lifting equipment

Here is how the DCG90-180 helps drivers optimize lifting efficiency and save fuel – at the same time. To begin with, its new electric and hydraulic systems mean quicker response, high lifting speed and increased control. Meanwhile, new load sensing hydraulic pumps improve fuel efficiency. Operating together, this combination improves productivity and saves fuel – every lift.

As lifting equipment plays a vital role in the performance of any forklift, it is important yours match your individual requirements and applications. For instance, careful consideration should be made to factors such as lift height, clearance, free lift, carriage flexibility, etc. in order to optimize operations.

Cargotec offer you a complete range of standard and custom lifting equipment – carriage, fork shaft, forks, levelling, etc – and options to suit your specific lifting and cargo handling requirements.

## Duplex standard, clear view

Lift height H4	Mast height		Free lift H2	Mast height		Free lift H2
	H3 min	H5 max		H3 min	H5 max	
3000	3015	4515	–	3195	4695	–
3250	3140	4765	–	3320	4945	–
3500	3265	5015	–	3445	5195	–
3750	3390	5265	–	3570	5445	–
4000	3515	5515	–	3695	5695	–
4500	3765	6015	–	3945	6195	–
5000	4015	6515	–	4195	6695	–
5500	4265	7015	–	4445	7195	–
6000	4515	7515	–	4695	7695	–
6500	4765	8015	–	4945	8195	–
7000	5015	8515	–	5195	8695	–



Duplex standard, free visibility

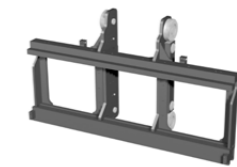

Fixed for manually moveable forks

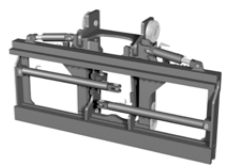

Centre levelling

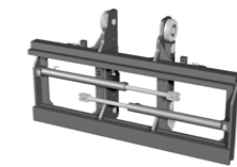

Fork positioning and sideshift



Sideshift

## Duplex full free lift, clear view

Lift height H4	Mast height		Free lift H2	Mast height		Free lift H2
	H3 min	H5 max		H3 min	H5 max	
3000	3015	4515	1500	3195	4695	1500
3250	3140	4765	1625	3320	4945	1625
3500	3265	5015	1750	3445	5195	1750
3750	3390	5265	1875	3570	5445	1875
4000	3515	5515	2000	3695	5695	2000
4500	3765	6015	2250	3945	6195	2250
5000	4015	6515	2500	4195	6695	2500
5500	4265	7015	2750	4445	7195	2750
6000	4515	7515	3000	4695	7695	3000
6500	4765	8015	3250	4945	8195	3250
7000	5015	8515	3500	5195	8695	3500



Duplex full free lift, free visibility



Forks for manual adjustment



Fork shaft system with separate carriers for each fork

## Triplex full free lift, clear view

Lift height H4	Mast height		Free lift H2	Mast height		Free lift H2
	H3 min	H5 max		H3 min	H5 max	
4500	2950	5950	1500	3130	6190	1500
5000	3117	6450	1667	3297	6690	1667
5500	3283	6950	1833	3463	7190	1833
6000	3450	7450	2000	3630	7690	2000
6500	3617	7950	2167	3797	8190	2167
7000	3783	8450	2333	3963	8690	2333

+25 mm on H3 and H5 on the DCG140

\* DCG90-140-6

\*\* DCG150-180-6, DCG160-9, DCG100-160-12



Triplex full free lift, free visibility



Roller fittings for hydraulic adjustment



Hydraulic levelling

# Drive train

## Engine range

You can equip the drive train of the new Kalmar DCG90-180 with one of two different diesel engines: from Volvo or Cummins. Both are powerful, durable, reduce fuel consumption and compliant with EU Stage IV / EPA Tier 4 final emissions.

Equipped with your choice of EU Stage IV / EPA Tier 4 final compliant diesel engine from Volvo or Cummins, your DCG90-180 engine offers many improvements. Both cut particulate emissions by 95% and reduce nitrogen oxide emissions by half. As important, both ensure maximum power and torque are available at low rpm as well as improve fuel efficiency without compromising operational reliability, durability or performance. The trucks are fitted with an efficient and easy-to-service split cooling system.

## Keeping clean and cool to reduce risks of failure

The truck's improved cooling system keeps the engine room cooler, which prolongs the lifetime of engine, hydraulic and electrical components. In addition, you keep the radiator clean from potentially harmful dirt, dust or particles by adding an optional reversible cooling fan.

## Transmission

The electronically controlled gearbox allows comfortable, efficient and safe driving at all speeds and operating lifting equipment with high precision. We offer a wide range of gearboxes to match your needs and preferences.

## SCR technology

Our Cummins and Volvo engines are equipped with the latest SCR technology.

The SCR engines are optimized for efficient combustion, which provides the fuel efficiency and low particulate emission benefits. To combat the resultant NOx emissions, AdBlue is injected into the exhaust gas. Exhaust gas and AdBlue then enter a catalytic converter, which turns the NOx into harmless nitrogen gas and water vapour. The cleaning process of the catalyst is done automatically by the system during normal driving.

## Drive and steering axle

The steering system utilizes a well-proven, robust design with a double acting cylinder and a pendulum suspension. This provides high strength and durability. The robust design of the drive axle handles extreme stresses from quick manoeuvring and/or normal operations in tough working environments with heavy loads, high intensity operations and even towing tasks. The drive axle has a two-stage reduction to ensure minimum strain on the transmission system – differential and hub reduction.

The AdBlue tank has a volume of 15 L and is equipped with a level sensor which notifies the driver when its time to fill up the tank. The filling of AdBlue is usually done together with the filling of diesel. The AdBlue tank is heated by engine coolant and the AdBlue hoses are heated by electricity to prevent freezing in cold climates. (Freezing point of AdBlue -11C). There is no increase in service intervals, no impact on uptime.

## Powerful braking

The service brake system is of the wet disc brake type, featuring one set of fixed and one set of rotating oil-cooled discs that are linked with hydraulic pressure from the brake pedal upon activation. This provides extremely effective and smooth braking over an extended period of time without risk of overheating or fading.



# Drive train and performance

Drive trains		Volvo TAD572 VE (160 kW) with ZF 3WG171	Cummins QSB6,7 (168 kW) with ZF 3WG171	Cummins QSB6,7* (129 kW) with ZF 3WG161
Engine	Manufacturer – type designation	Volvo - TAD572VE (Turbo-Intercooler)	Cummins QSB6,7 (Turbo-Intercooler)	Cummins QSB6,7 (Turbo-Intercooler)
	Fuel – type of engine	Diesel – 4-stroke	Diesel – 4-stroke	Diesel – 4-stroke
	Rating ISO 3046 – at revs (kW/hp – rpm)	160/218 – 2300	168/228 – 2200	129/176 – 2200
	Peak torque ISO 3046 – at revs (Nm – rpm)	910 – 1200	949 – 1500	800 – 1400
	Number of cylinders – displacement (cm³)	4 – 5100	6 – 6702	6 – 5900
	Fuel consumption, normal driving (l/h)	7-9	7-9	8-10
	AdBlue consumption, normal driving (l/h)	0,3	0,3	0,3 / N/A
	Emission standard	Stage IV / Tier 4 final	Stage IV / Tier 4 final	Stage IV & IIIB
Gearbox	Manufacturer – type designation	ZF – 3WG171	ZF – 3WG171	ZF – 3WG161
	Clutch, type	Torque converter	Torque converter	Torque converter
	Gearbox, type	Hydrodynamic Powershift	Hydrodynamic Powershift	Hydrodynamic Powershift
	Numbers of gears, forward – reverse	3 – 3	3 – 3	3 – 3
Alternator	Type – power (W)	AC – 3080	AC – 1960	AC – 1680
Starting battery	Voltage – capacity (V – Ah)	2x12 – 150	2x12 – 150	2x12 – 150
Driving axle	Manufacturer – type	Kessler D81 – Differential and hub reduction	Kessler D81 – Differential and hub reduction	Kessler D81 – Differential and hub reduction

\*Cummins QSB6,7 (129 kW) is available in both Stage IIIB & IV. The Stage IIIB version does not require AdBlue.

Performance – Volvo TAD572 VE (160 kW)		DCG 90-6	DCG 100-6	DCG 120-6	DCG 127-6	DCG 140-6	DCG 150-6	DCG 100-12	DCG 120-12	DCG 150-12	DCG 160-6	DCG 160-9	DCG 160-12	DCG 180-6	DCG 70-32 E3	DCG 70-35 E4
Lifting speed	Unloaded (m/s)	0,50	0,50	0,40	0,40	0,40	0,40	0,40	0,40	0,40	0,40	0,40	0,40	0,40	0,50	0,60
	At rated load (m/s)	0,45	0,45	0,35	0,35	0,35	0,35	0,35	0,35	0,35	0,35	0,35	0,35	0,35	0,45	0,55
Lowering speed	Unloaded (m/s)	0,40	0,40	0,40	0,40	0,40	0,40	0,40	0,40	0,40	0,40	0,40	0,40	0,40	0,50	0,50
	At rated load (m/s)	0,40	0,40	0,40	0,40	0,40	0,40	0,40	0,40	0,40	0,40	0,40	0,40	0,40	0,50	0,50
Travelling speed, F/R	Unloaded (km/h)	29	29	29	29	29	29	29	29	29	29	29	29	29	29	29
	At rated load (km/h)	28	28	27	28	28	28	28	27	27	27	27	27	27	28	28
Gradeability, max.	Unloaded (%)	>120	>120	>120	114	111	82	91	83	68	86	73	68	71	65	62
	At rated load (%)	63	59	52	47	44	39	49	43	36	38	36	35	33	46	44
Gradeability, at 2 km/h	Unloaded (%)	103	98	91	82	81	63	69	64	54	66	58	54	56	52	49
	At rated load (%)	50	47	42	39	37	32	40	35	30	32	30	29	28	38	37
Drawbar pull	Max. (kN)	127	127	127	123	123	123	123	123	123	123	123	123	123	123	123
Noise level, inside	L <sub>paZ</sub> , EGO cabin (dB(A))	71	71	71	71	71	71	71	71	71	71	71	71	71	71	71
	L <sub>paZ</sub> , EGO cabin OHG (dB(A))	83	83	83	83	83	83	83	83	83	83	83	83	83	83	83
Noise level, outside	L <sub>wa</sub> ** (dB(A))	109	109	109	109	109	109	109	109	109	109	109	109	109	109	109

\* L<sub>paZ</sub> according to EN12053 \*\* L<sub>wa</sub> according to 2000/14/EC

Performance – Cummins QSB6,7 (168 kW)		DCG 90-6	DCG 100-6	DCG 120-6	DCG 127-6	DCG 140-6	DCG 150-6	DCG 100-12	DCG 120-12	DCG 150-12	DCG 160-6	DCG 160-9	DCG 160-12	DCG 180-6	DCG 70-32 E3	DCG 70-35 E4
Lifting speed	Unloaded (m/s)	–	0,50	0,40	0,40	0,40	0,40	0,40	0,40	0,40	0,40	0,40	0,40	0,40	0,5	0,6
	At rated load (m/s)	–	0,45	0,35	0,35	0,35	0,35	0,35	0,35	0,35	0,35	0,35	0,35	0,35	0,45	0,55
Lowering speed	Unloaded (m/s)	–	0,30	0,30	0,30	0,30	0,30	0,30	0,30	0,30	0,30	0,30	0,30	0,30	0,5	0,5
	At rated load (m/s)	–	0,40	0,40	0,40	0,40	0,40	0,40	0,40	0,40	0,40	0,40	0,40	0,40	0,5	0,5
Travelling speed, F/R	Unloaded (km/h)	–	29	29	30	30	30	30	30	30	30	30	30	30	30	30
	At rated load (km/h)	–	27	27	28	28	27	28	28	27	27	27	27	27	28	28
Gradeability, max.	Unloaded (%)	–	>120	>120	118	115	84	94	85	70	89	75	69	73	67	63
	At rated load (%)	–	60	53	48	45	39	50	44	36	39	36	35	34	47	45
Gradeability, at 2 km/h	Unloaded (%)	–	88	82	75	73	58	64	59	50	61	53	50	52	48	46
	At rated load (%)	–	44	39	36	34	30	37	33	28	30	28	27	26	35	34
Drawbar pull	Max. (kN)	–	129	129	125	125	125	125	125	125	125	125	125	125	125	125
Noise level, inside	L <sub>paZ</sub> , EGO cabin (dB(A))	–	73	71	71	71	71	71	71	71	71	71	71	71	71	71
	L <sub>paZ</sub> , EGO cabin OHG (dB(A))	–	83	83	83	83	83	83	83	83	83	83	83	83	83	83
Noise level, outside	L <sub>wa</sub> ** (dB(A))	–	108	108	108	108	108	108	108	108	108	108	108	108	108	108

\* L<sub>paZ</sub> according to EN12053 \*\* L<sub>wa</sub> according to 2000/14/EC

Performance – Cummins QSB6,7 (129 kW)		DCG 90-6	DCG 100-6	DCG 120-6	DCG 127-6	DCG 140-6	DCG 150-6	DCG 100-12	DCG 120-12	DCG 150-12	DCG 160-6	DCG 160-9	DCG 160-12	DCG 180-6	DCG 70-32 E3	DCG 70-35 E4
Lifting speed	Unloaded (m/s)	0,50	0,50	0,40	0,40	0,40	0,40	0,40	0,40	0,40	0,40	0,40	0,40	0,40	0,50	0,60
	At rated load (m/s)	0,45	0,45	0,35	0,35	0,35	0,35	0,35	0,35	0,35	0,35	0,35	0,35	0,35	0,45	0,55
Lowering speed	Unloaded (m/s)	0,40	0,40	0,40	0,40	0,40	0,40	0,40	0,40	0,40	0,40	0,40	0,40	0,40	0,50	0,50
	At rated load (m/s)	0,40	0,40	0,40	0,40	0,40	0,40	0,40	0,40	0,40	0,40	0,40	0,40	0,40	0,50	0,50
Travelling speed, F/R	Unloaded (km/h)	29	29	29	29	29	29	29	29	29	29	29	29	29	29	29
	At rated load (km/h)	28	28	27	28	28	28	28	28	27	27	27	27	27	28	28
Gradeability, max.	Unloaded (%)	>120	>120	>120	107	104	78	87	79	65	82	70	65	68	63	59
	At rated load (%)	–	57	50	45	43	37	47	41	34	37	34	33	32	44	43
Gradeability, at 2 km/h	Unloaded (%)	–	97	91	79	78	61	67	62	52	64	56	52	54	50	48
	At rated load (%)	–	47	41	37	35	31	39	34	29	30	29	28	27	37	35
Drawbar pull	Max. (kN)	109	109	109	104	104	104	104	104	104	104	104	104	104	104	104
Noise level, inside	L <sub>paZ</sub> , EGO cabin (dB(A))	73	73	73	73	73	73	73	73	73	73	73	73	73	73	73
	L <sub>paZ</sub> , EGO cabin OHG (dB(A))	85	85	85	85	85	85	85	85	85	85	85	85	85	85	85
Noise level, outside	L <sub>wa</sub> ** (dB(A))	108	108	108	108	108	108	108	108	108	108	108	108	108	108	108

\* L<sub>paZ</sub> according to EN12053 \*\* L<sub>wa</sub> according to 2000/14/EC

# Advanced electronics and proven power train

More intelligence means more uptime. The new DCG90-180 incorporates an improved electronics system with reduced fault sources. Its modern distributed and redundant CAN-bus technology continuously controls the truck's condition while providing the driver with real-time data.

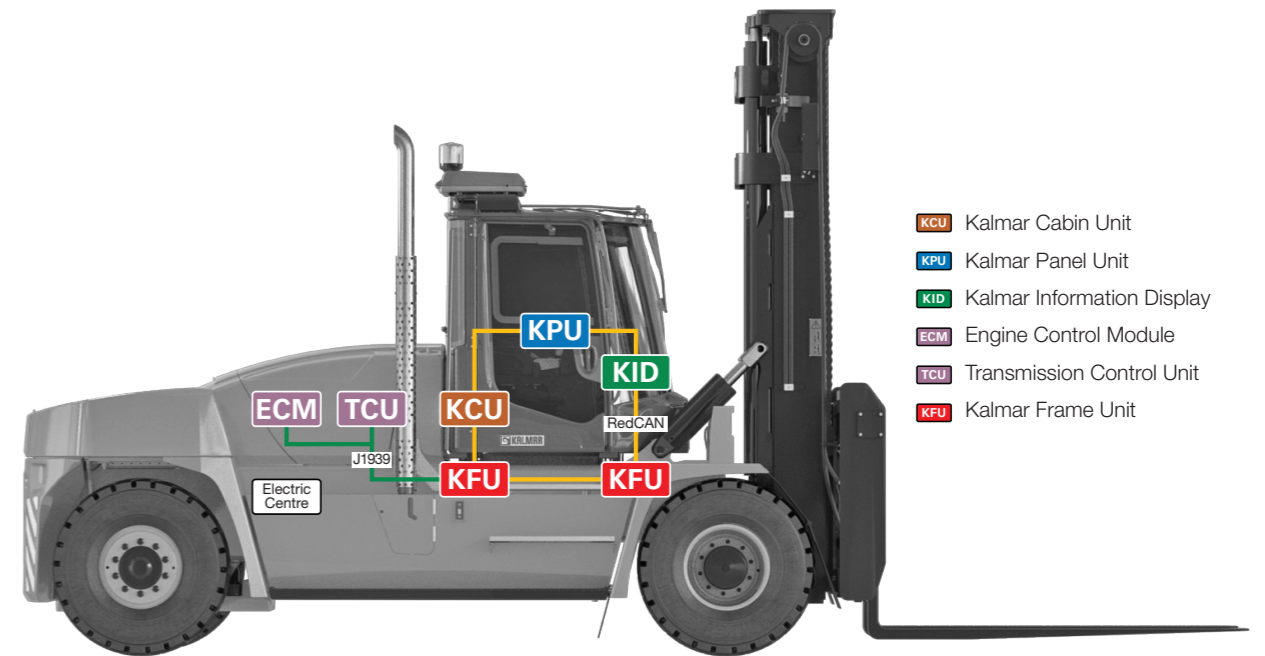

## Electronics system

Kalmar's electronic system is a fast, intelligent and stable system that makes the truck more reliable and user-friendly. The improved electronics utilize far fewer connection points and cabling, which means fewer potential fault points and improved

operational reliability. A modern, distributed and redundant CAN-bus (Controller Area Network) monitors and controls the condition and performance of the engine, gearbox, valves and some 500 measuring points in the engine – 50 times every second.

The CAN-bus also keeps driver well informed of the truck's status by sending real-time condition monitoring data to a 3.5" colour display that is placed at eye level in the cabin.

# Saving maintenance time & effort

Fast, simple and more convenient daily inspections and regular servicing was prioritized and achieved in developing the new DCG90-180. An array of new built-in features saves maintenance time, effort and costs.



## Daily inspections and regular servicing

Performing daily inspections and regular servicing takes just a few minutes. Here are some of the many built-in maintenance improvements in the DCG90-180:

- Easy to get to location of the electric cabinet
- All hydraulic oil filters can be reached from above at one location
- A special drain for shaft oil makes it possible to fill oil while standing

All daily inspection checkpoints are directly accessible at ground level from the side of the truck.



Electric cabinet is easily accessible.



Improved placement of hydraulic filters.

## Wear and spare part savings

The DCG90-180's usage of well-proven assemblies, systems, units and components also means low part failure rates, thereby promoting savings in wear and spare parts. Furthermore, Kalmar manages an advanced and extensive distribution network. This offers you simple sourcing and rapid availability of high-quality, original parts. Our local, dedicated customer service teams provide Just-In-Time deliveries, quick response as well as the right level of support to your business. Kalmar stays close to you – wherever you are – to help keep your cargo on the move.

## 500 hours of driving

Well-proven assemblies, systems, units and components have been extensively used in the DCG90-180. This ensures long service intervals of 500 hours. This matches the top performance levels in the industry.



Shaft oil filling plug.

# The Kalmar difference

## Superior truck-and-driver productivity

- New EGO cabin is our most productive working environment – ever. It's loaded with improved ergonomic features to inspire driver productivity, efficiency and safety.
- New electric and hydraulic systems as well as modern lifting equipment help drivers boost productivity levels whilst reducing fuel consumption

- The improved electronic system is a fast, intelligent and stable system that ensures truck uptime and operational reliability. There are far fewer connection points and cables, thus significantly reducing potential fault sources.
- A distributed and redundant CAN-bus system continuously monitors the truck's condition. It sends real-time condition monitoring data to the driver via a 3.5" colour display in the cabin.



EGO cabin.



Cummins QSB6,7 engine.



Fuel efficiency.

## Operational and maintenance savings

- Your choice of EU StageIV/EPA Tier 4 final compliant diesel engines from Volvo or Cummins. Both engines feature new advances that improve fuel efficiency.
- New load sensing pumps boost lifting productivity and lower fuel consumption.
- Dozens of new features save maintenance time, effort and costs.

## Parts, resale value and customization: more ways to save

- Well-proven assemblies, systems, units and components
- Kalmar's distribution network and local support teams ensure fast, professional service
- High quality of the Kalmar brand secures high resale value
- Customize your truck to ideally suit your needs: Kalmar offers full support.





Kalmar offers the widest range of cargo handling solutions and services to ports, terminals, distribution centres and to heavy industry. Kalmar is the industry forerunner in terminal automation and in energy efficient container handling, with one in four container movements around the globe being handled by a Kalmar solution. Through its extensive product portfolio, global service network and ability to enable a seamless integration of different terminal processes, Kalmar improves the efficiency of every move. [www.kalmarglobal.com](http://www.kalmarglobal.com)

Kalmar is part of Cargotec. Cargotec's sales totalled approximately EUR 3.2 billion in 2013 and it employs approximately 11,000 people. Cargotec's class B shares are quoted on NASDAQ OMX Helsinki under symbol CGCBV. [www.cargotec.com](http://www.cargotec.com)

Cargotec Sweden AB  
Torggatan 3  
SE-340 10, Lidhult, Sweden  
tel. +46 372 260 10